

Model Number: NE25VTA-04  
 Description: Vifa RM 25mm Tweeter "Aluminum"

Revision: rev 2\_0  
 Date: 31-Aug-09



The Vifa NE product line has leading-edge transducer technology packaged in a cutting edge, stylistic design. The tweeters in this product line finite element analysis designed Neodymium-Iron-Boron magnet (NdFeB) motors, with copper caps for extended frequency response and reduced distortion. The aluminium rear chambers offer extended low frequency performance, while doubling as heat sinking. The butterfly supporting the tweeter diaphragm is made of a high temperature plastic, consistent with the product's high temperature performance rating, and features supporting terminals. The dome material in this design is aluminum, and the design has been optimized for sound quality and clarity. Rounding out the design is an aluminium face plate and plastic grille, which offers protection for the tweeter diaphragm.



**Mechanical 2D Drawing:**

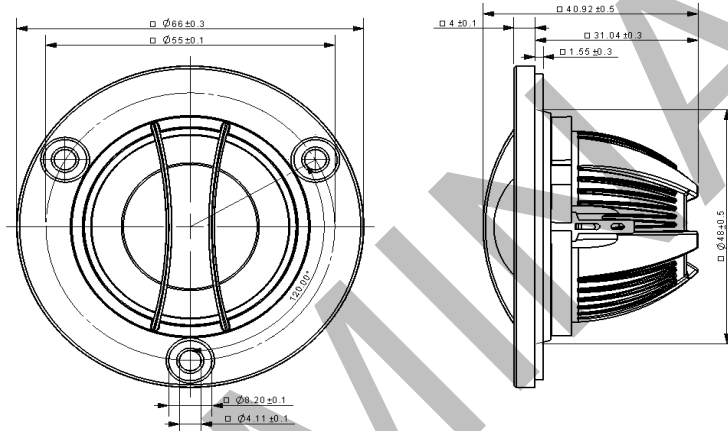

**Specifications:**

DC Resistance	$R_{eVC}$	$\Omega$	3.2	Energy Bandwidth Product	EBP	$(1/Q_{es})f_s$	540
Minimum Impedance	$Z_{min}$	$\Omega$	3.53	Moving Mass	$M_{ms}$	g	0.37
Voice Coil Inductance	$L_e$	mH	0.04	Suspension Compliance	$C_{ms}$	um/N	132.6
Resonant Frequency	$f_s$	Hz	716	Effective Cone Diameter	D	cm	3.2
Mechanical Q Factor	$Q_{ms}$	-	3.6	Effective Piston Area	$S_D$	cm <sup>2</sup>	8.0
Electrical Q Factor	$Q_{es}$	-	1.33	Equivalent Volume	$V_{as}$	L	0.01
Total Q Factor	$Q_{ts}$	-	0.97	Motor Force Factor	BL	T-m	2.00
Ratio $f_s / Q_{es}$	F	$f_s / Q_{es}$	738	Motor Efficiency Factor	$\beta$	$(T \cdot m^2) / \Omega$	1.26
Half Space Sensitivity @ 2.83V	dB@2.83V/1m	dB	91.5	Voice Coil Former Material	$VC_{fm}$	-	Alu
Rated Noise Power (IEC 2685 18.1)	P	W	80	Voice Coil Inner Diameter	$VC_d$	mm	25.8
Test Spectrum Bandwidth	2khz - 20khz	12 dB/Oct		Maximum Linear Excursion	$X_{max}$	mm	0.10
				Transducer Mass	-	kg	0.1

**Frequency and Impedance Response:**

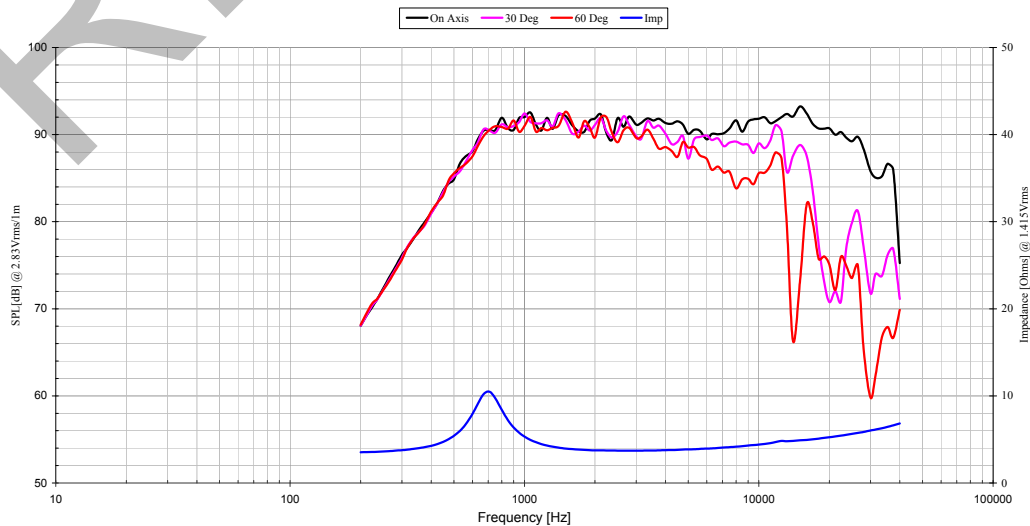

F088-0713A