

**TW** SERIES**28-847SE**

## 28mm FABRIC DOME

- SOFT FABRIC DOME DIAPHRAGM COATED WITH HIGH LOSS MATERIAL
- FERROFLUID COOLED
- WOOL IN CAVITY OF POLE PIECE
- NYLON(15% GF) FRONT PANEL & BACK CHAMBER
- MAGNETICALLY SHIELDED
- BACK CHAMBER DESIGN

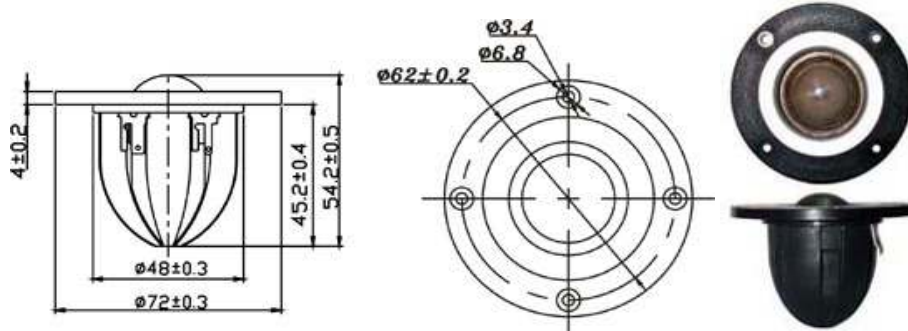

DIAPHRAGM MTL	Fabric
SURROUND MTL	N/A
NOMINAL IMPEDANCE	8 Ω
DCR IMPEDANCE	6 Ω
SENSITIVITY 1W/1m	90 dB
FREQUENCY RESPONSE	850-20K Hz
FREE AIR RESONANCE	850 Hz
VOICE COIL DIAMETER	28 mm
AIR GAP HEIGHT	2 mm
RATED POWER INPUT	12 W
MAXIMUM POWER INPUT	100 W
FORCE FACTOR, BL	N/A
MAGNET WEIGHT ( oz)	Neodymium
MOVING MASS	N/A
FERRO FLUID ENHANCED	Yes
SUSPENSION COMPL.	N/A
EFFEC.PISTON AREA	N/A
Levc	0.016mH
Zo	16ohm
X-max	0.26mm
Vas	N/A
Qts	N/A
Qms	N/A
Qes	N/A

**TB** SPEAKERS

VOICE:886.2.26570282 FAX:886.2.26580166  
E-MAIL: info@tb-speaker.com

**CLOSE**